



solar shower 35L

instruction manual

D35S

HY-CLOR AUSTRALIA PTY LIMITED
ABN 81 000 655 381

178 Power Street
Glendenning NSW 2761 Australia

all enquiries:
AU 1800 625 123, NZ (09) 973 2477
or help@hyclor.com.au

visit us at hyclor.com.au

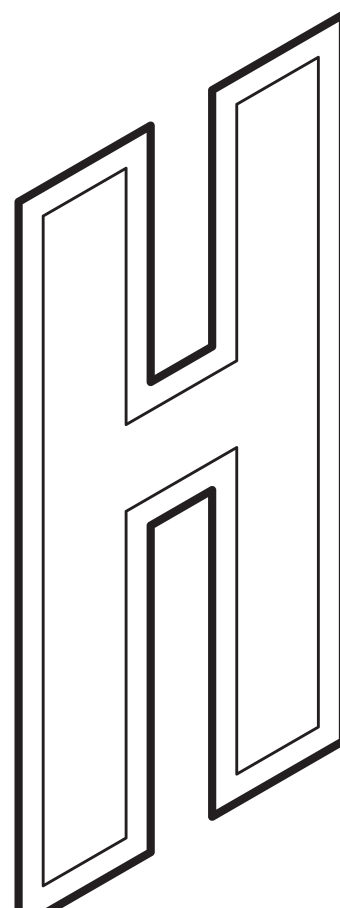



IMPORTANT: READ THE FOLLOWING INSTRUCTIONS CAREFULLY BEFORE ASSEMBLING THE SOLAR SHOWER.

We recommend installation of the Outdoor Solar Shower to a solid surface to insure stability and safety.

When using tools, care must be taken not to damage chrome plating.

We recommend using a cloth between wrench and shower parts to avoid damage.

MOUNTING THE SOLAR SHOWER: CONCRETE/ MASONRY INSTALLATION ONLY

1. Choose a location for shower that receives the most direct sunlight.
2. Use the base plate/PVC tube to mark the position of the mounting holes to be drilled into concrete/ masonry for bolts.
3. Remove shower section. Drill 12mm diameter holes with a depth of 60mm, using the marks just created.
4. Insert expansion nuts into drilled holes. Place the bolt inside the expansion nut and TAP with a hammer to slightly expand the nut.
5. Remove bolt and place the base plate/lower tube over the holes and secure to surface with bolts and washers provided.

NOTE: Base plate will appear loose until shower is fully secured to the surface.

If not using masonry instalation use our Hy-Clor Solar Shower Stand. SKU: SWMSHOWSTND.



DUE TO THE SOLAR RADIATION THE WATER IN THE SOLAR TANK CAN GET HOT.

WE RECOMMEND OPENING THE HANDLE IN THE MIDDLE POSITION BETWEEN HOT AND COLD, THEN SETTING TO DESIRED TEMPERATURE.

IF SHOWER HAS NOT BEEN USED FOR MORE THAN THREE DAYS, WE RECOMMEND RUNNING SOLAR SHOWER FOR 2 MINUTES TO REMOVE STAGNANT WATER. STAGNANT WATER IN A WARM ENVIRONMENT CAN PROVIDE A GROWTH ENVIRONMENT FOR HAZARDOUS BACTERIA.

USING THE SHOWER:

The Solar shower is equipped with a mixing valve, where the first cold water and then hot water is flowing. The valve must not be over tightened, since this may be damaged irreparable.

Connect the water hose to the shower and let the water warm up by the sun. (12 to 24 hours, depending on the ambient temperature and solar radiation) Once the water is hot, open the valve until the desired temperature is reached.

To fill the solar tank, turn the valve to hot and wait until the shower is completely filled. Once filled, close the valve and let the warm water warm up for several hours.

When the water drips furthermore with a closed mixer, it is possible that the water pressure is too high. Reduce this by fitting in a pressure regulator.

OFF SEASON DISASSEMBLY & STORAGE:

DURING THE WINTER THE WATER HAS TO BE REMOVED FROM THE SOLAR SHOWER COMPLETELY. FURTHERMORE THE SOLAR SHOWER HAS TO BE TAKEN DOWN IN WINTER AND STORED IN A DRY PLACE. FAILURE TO FOLLOW THESE INSTRUCTIONS MAY CAUSE FROST DAMAGE ON MATERIAL -> FROST DAMAGE WILL NOT BE RECOGNIZED AS A CLAIM.

1. Turn off and disconnect garden hose.
2. Open handle and allow shower to drain (approximately 2 minutes).
3. Turn lock nut COUNTER CLOCKWISE to unthread, and pull stainless steel pipe apart.
4. Unbolt shower PVC tube and pour remaining water out of unit.
5. Wipe down and store shower parts for next season.

DO NOT USE SALT OR ANTI-FREEZE IN WATER TO PREVENT FREEZING. THIS WILL VOID THE PRODUCT WARRANTY.

Keep this manual. Please include the manual with the product upon transfer of ownership.

PRODUCT HELPLINE

**Australia: 1800 625 123
New Zealand: (09) 973 2477**

**help@hyclor.com.au
www.hyclor.com.au**

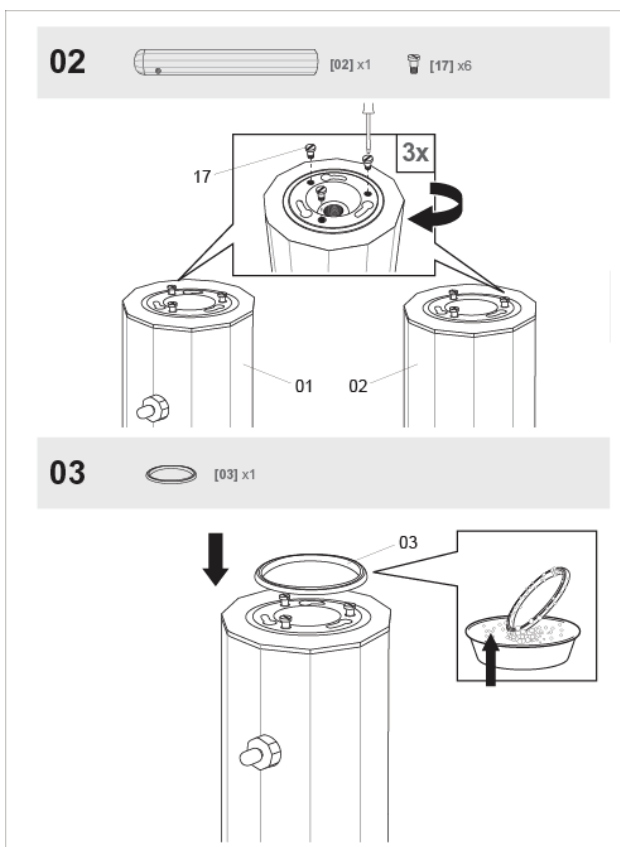
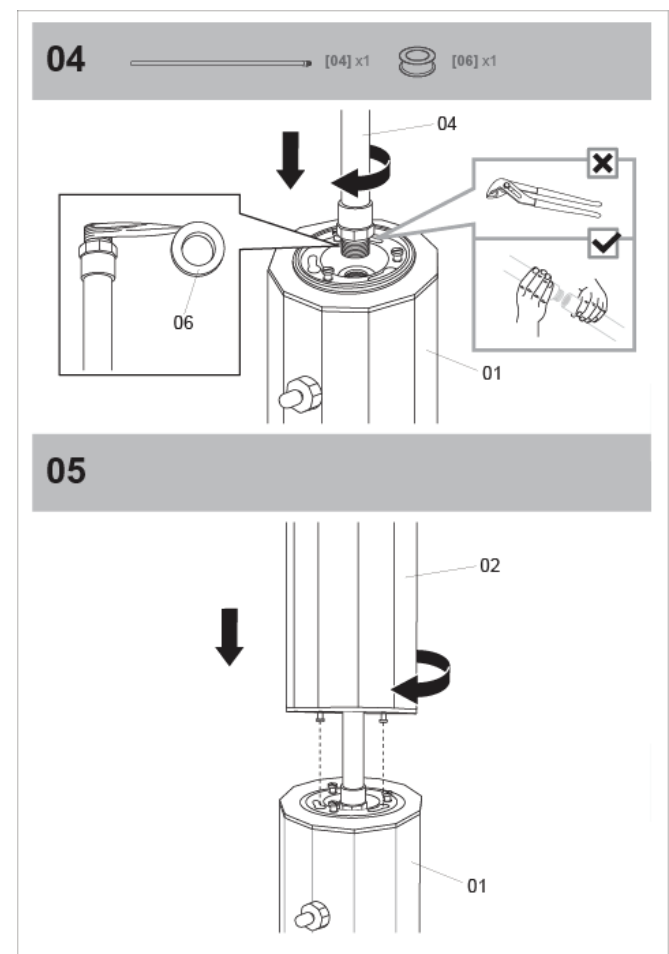
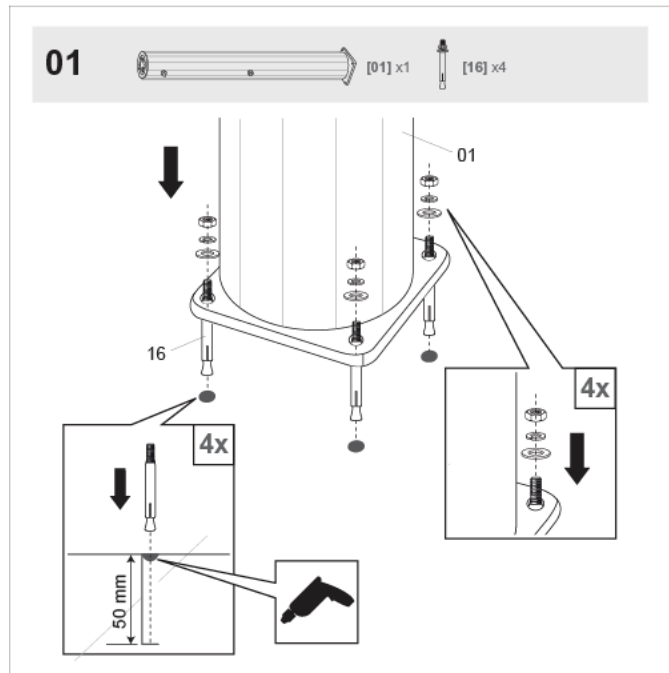
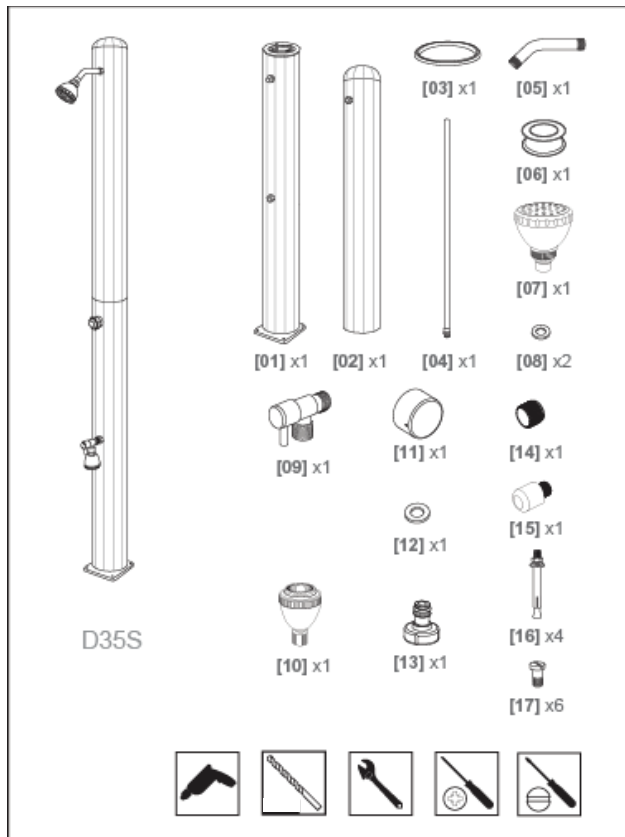

PRODUCT HELPLINE

Australia: 1800 625 123
New Zealand: (09) 973 2477

help@hyclor.com.au
www.hyclor.com.au

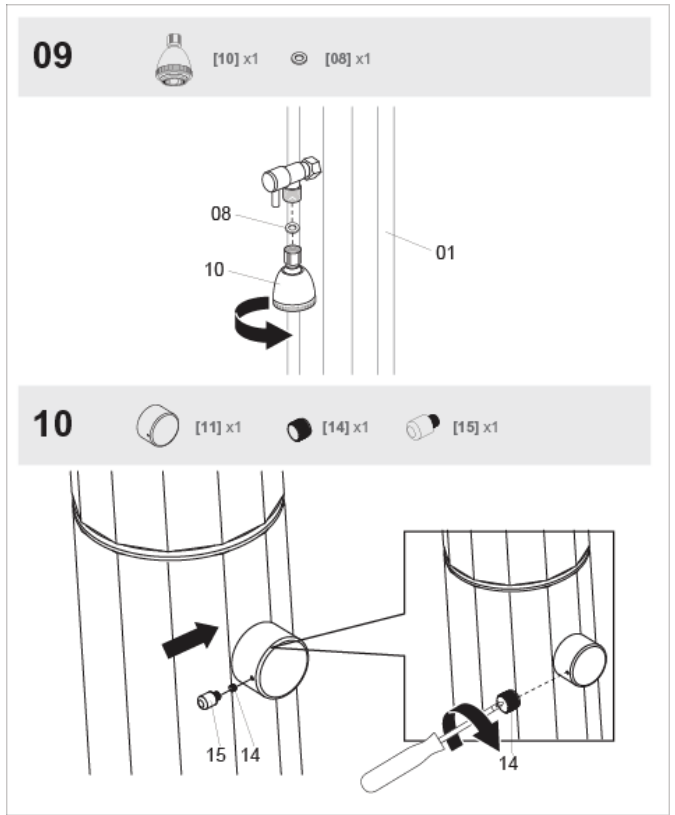
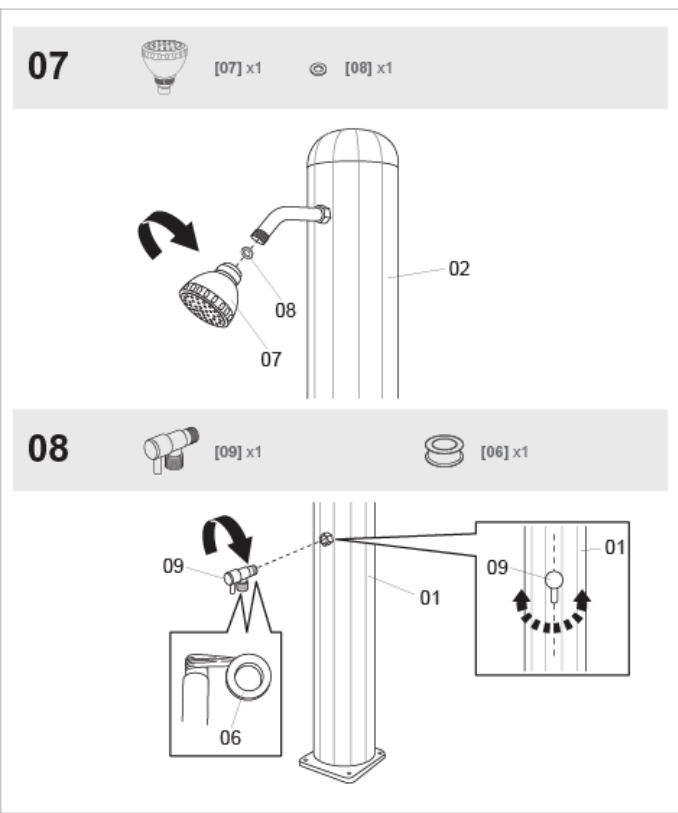
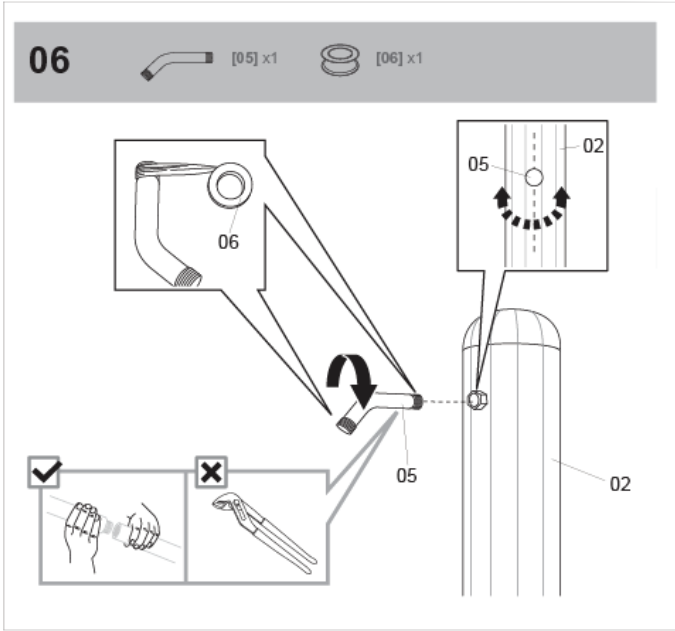

PRODUCT HELPLINE

Australia: 1800 625 123
 New Zealand: (09) 973 2477

help@hyclor.com.au
 www.hyclor.com.au



WARRANTY CERTIFICATE

Warranty Terms and Conditions

This Warranty is provided by HY-CLOR Australia Pty Limited (ABN 81000655381), 178 Power Street, Glendenning NSW 2761 and is subject to the Australian Competition and Consumer Act 2010. The benefits provided to you by this Warranty are in addition to other rights and remedies available to you under the Australian Consumer Law. The Warranty period commences on the date of purchase of the product.

Consumer Guarantee

Our products come with guarantees that cannot be excluded under the Australian Consumer Law. You are entitled to a replacement or refund for a major failure and compensation for any other reasonably foreseeable loss or damage. You are also entitled to have the product repaired or replaced if the product fails to be of acceptable quality and the failure does not amount to a major failure.

Products used outside of a domestic environment will void this Warranty.

Exclusions

This Warranty will not apply **without a Proof of Purchase**. Also if the product has not been installed, used or maintained in accordance with the manufacturer's instructions supplied with the product.

Normal wear and tear to the product or parts is not covered by this Warranty.

PRODUCT HELPLINE

Australia: 1800 625 123
New Zealand: (09) 973 2477

help@hyclor.com.au
www.hyclor.com.au

Warranty Period

PRODUCTS	WARRANTY
• D8L Outdoor Shower	12 months
• D9HS Handheld Shower	12 months
• SS0912 Outdoor Shower	12 months
• D20L Outdoor Shower	12 months
• D35S Outdoor Shower	12 months
• 1560 Shower Stand	12 months

To Make a Claim

Please contact the **HY-CLOR Helpline AUS: 1800 625 123 NZ: (09) 973 2477** and a replacement/refund will be arranged **with your Proof of Purchase**.

PRODUCT NAME: _____ **MODEL NUMBER:** _____

DATE OF PURCHASE: _____ **RECEIPT NUMBER:** _____

CUSTOMER NAME: _____

ADDRESS: _____

EMAIL: _____ **PHONE NUMBER:** _____

Please attach a copy of your receipt, showing the date of purchase, to this Warranty Certificate and keep for your reference.

PRODUCT HELPLINE

Australia: 1800 625 123
New Zealand: (09) 973 2477

help@hyclor.com.au
www.hyclor.com.au



HY-CLOR AUSTRALIA PTY LTD
ABN: 81 000 655 381

178 Power Street
Glendenning, NSW 2761 Australia

Australia: 1800 625 123
New Zealand: (09) 973 2477

help@hyclor.com.au
www.hyclor.com.au

PRODUCT HELPLINE

Australia: 1800 625 123
New Zealand: (09) 973 2477

help@hyclor.com.au
www.hyclor.com.au