

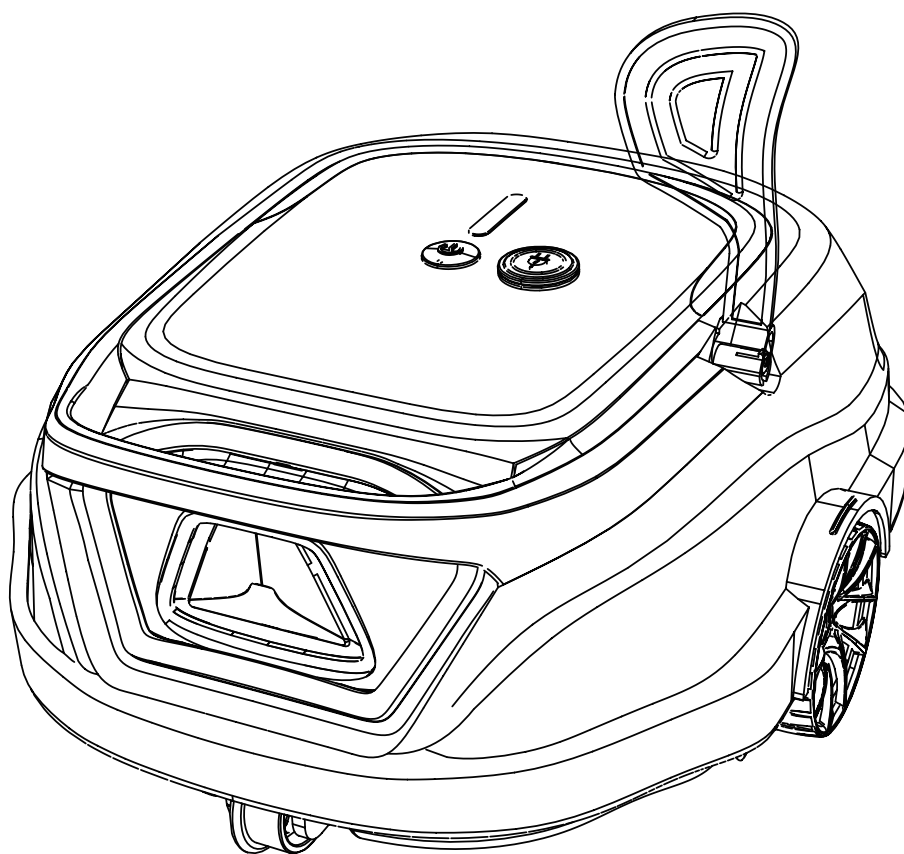

i1

CORDLESS ROBOTIC POOL CLEANER



INSTALLATION & OPERATION MANUAL

HY-CLOR AUSTRALIA PTY LIMITED
ABN 81 000 655 381

178 Power Street
Glendenning NSW 2761 Australia

all enquiries:
AU 1800 625 123, NZ (09) 973 2477
or help@hyclor.com.au

visit us at hyclor.com.au

Suits:
HYCROBOTi1

Version 1.0



Thank you for choosing the Hy-Clor i1 cordless robot cleaner. At Hy-Clor we are dedicated to making pool care easier and more affordable.

The i1 cleaner has been designed to be very easy to use and lightweight. It is one of, if not the lightest cleaners on the market, making it easy to lift in and out of the pool. The intelligent self-parking system, dual layer fine filtration, 4 cleaning modes, 7 day timer, and quick charging, make this pool cleaning robot exceptional value for money.

Should you need any information or guidance on this product, feel free to contact Hy-Clor at help@hyclor.com.au or 1800 625 123

Contents

WARNINGS / CAUTION	3
HY-CLOR I1 AT A GLANCE	4
Product External Overview	4
Product Internal Overview	5
Carton content	5
GET STARTED	6
Install flipper	6
Charge your new Hy-Clor i1	6 – 7
Setup your new Hy-Clor i1	7
Select your cleaning cycle	8
Run your new Hy-Clor i1	9 – 10
How to clean the Hy-clor i1	11
DEVICE SPECIFICATION	12
HOW TO MAINTAIN YOUR DEVICE	12
HOW TO ADJUST THE CLEANING PATTERN	13
FAQ & TROUBLESHOOTING	14
WARRANTY TERMS & CONDITIONS	15

PRODUCT HELPLINE

AU: 1800 625 123
NZ: (09) 973 2477

help@hyclor.com.au
www.hyclor.com.au



Read the manual carefully before you use the cleaner. Your safety is the most important thing. Please read through and operate the device as per instructions, HY-CLOR is not held liable for any loss or injury caused by improper use.

Warning

Failure to operate the device as per the warnings can result in serious injury, electrocution or death.

1. Only use original accessories as supplied by Hy-Clor
2. **Dry the charging port after each cleaning cycle. Do not charge the cleaner if the port is wet - will void warranty. Humidity inside port may cause an electric shock.**
3. **Do not charge the cleaner when it is running (the indicator is on).**
4. Avoid charging any other devices with this charger. Improper use may result in overheating or corrosive liquid leakage from the battery.
5. Make sure the electrical outlet is protected by a ground fault circuit interrupter (GFCI) and an earth leakage interrupter (ELI).
7. Do not use an extension cord to connect to the charger.
8. Never allow children to ride on the cleaner or play with it as a toy.
9. Do not allow children to operate or maintain the device.
10. Do not enter the pool when the cleaner is working.
11. Never expose or charge the device in a flammable environment.
12. Only licensed professionals can disassemble the sealed parts of the (motor and battery) of the i1 cleaner.
13. Do not operate the cleaner while pool filter is running.

Caution

1. Charge the unit before first use.
2. Be careful when touching any moving parts., such as the flipper hinge. Sudden movement could result in injury.
3. To avoid damage, disassemble the flipper during storage.
4. Do not over-charge the cleaner. Over-charging will reduce battery life.
5. To maintain optimal battery performance, charge the cleaner prior to extended storage (over 3 months).
6. Remember to wash and clean the filter trays after each use.
7. Store the cleaner in a cool and ventilated place, away from direct sunshine or any heat source.
8. Unbalanced water conditions will damage your cleaner. Maintain water balance at these levels:

Chlorine	Up to 4ppm
pH	7.0 - 7.8
Temperature	5 - 35 °C
NaCl (Salinity)	Maximum 5000 PPM

9. The i1 is not designed to clean Algae or fine dust from the pool.
10. The i1 cleaner is designed to keep a clean pool clean.

PRODUCT HELPLINE

AU: 1800 625 123
NZ: (09) 973 2477

help@hyclor.com.au
www.hyclor.com.au



Hy-Clor i1 at a glance

Product External Overview

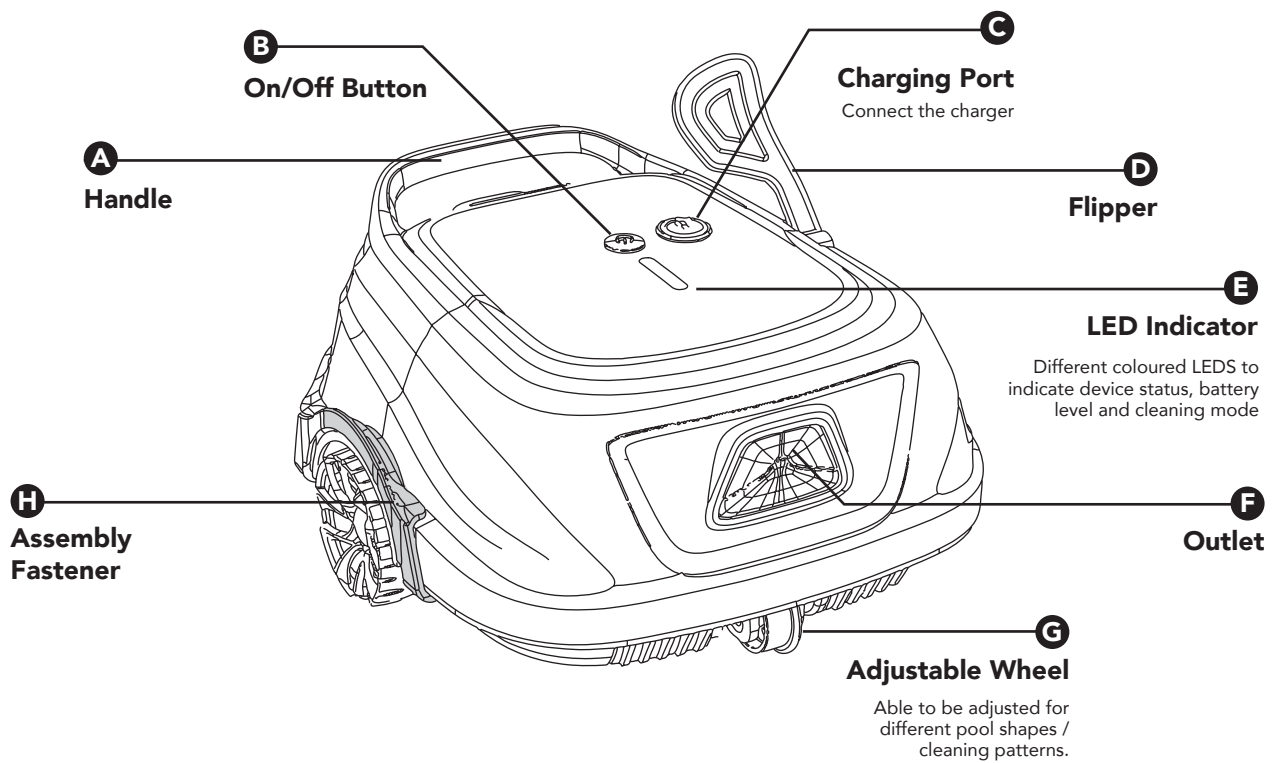

PRODUCT HELPLINE

AU: 1800 625 123
NZ: (09) 973 2477

help@hyclor.com.au
www.hyclor.com.au



Product Internal Overview

J

Sealed Motor + Battery

The internal battery and motor are housed within this compartment. For your safety, do not open or disassemble the sealed parts without authorisation.

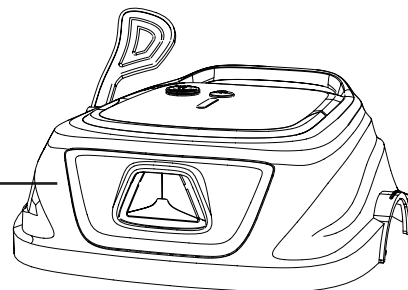

K

Filter Tray (sponge)

This filters out fine debris. Note, it can become clogged quickly if there is a lot of fine debris in the pool. A clogged filter tray/sponge will affect performance so clean regularly.

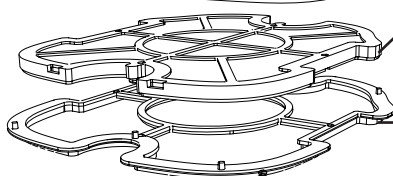

L

Filter Tray (180µm)

Can be used independently or combined with the sponge tray to trap the finest dirt.

M

Storage Cavity

Stores all collected debris - use a hose to clean out.

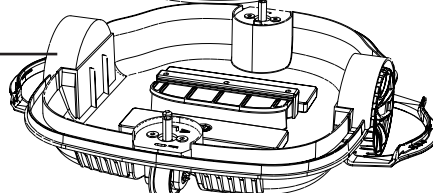

Do not use the device if the lid is damaged. Cease charging or operating the device if there is any liquid leaking from the sealed motor assembly. Contact Hy-clor for assistance.

Carton contents

Item	Description	Qty
1	Device	1
2	Flipper & End Cap	1
3	Filter tray +180µm	2
4	Charger	1
5	Hook	1
6	User Manual	1
7	Quick Guide	1
N/A	Spare flipper screw	1

1

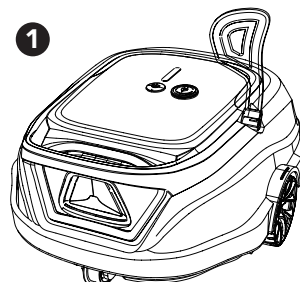

2

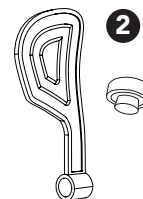

3

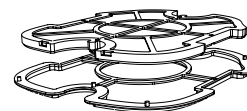

4

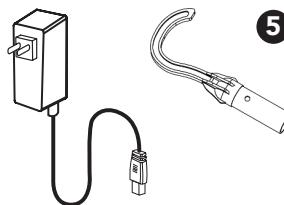

5

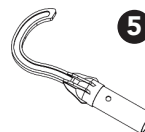

6



7

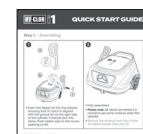

PRODUCT HELPLINE

AU: 1800 625 123
NZ: (09) 973 2477

help@hyclor.com.au
www.hyclor.com.au



Get Started

Install flipper

You need to insert the included flipper into the cleaner with the notch and groove being aligned. It will click into place. Once the flipper is securely inserted, add the rubber end cap.

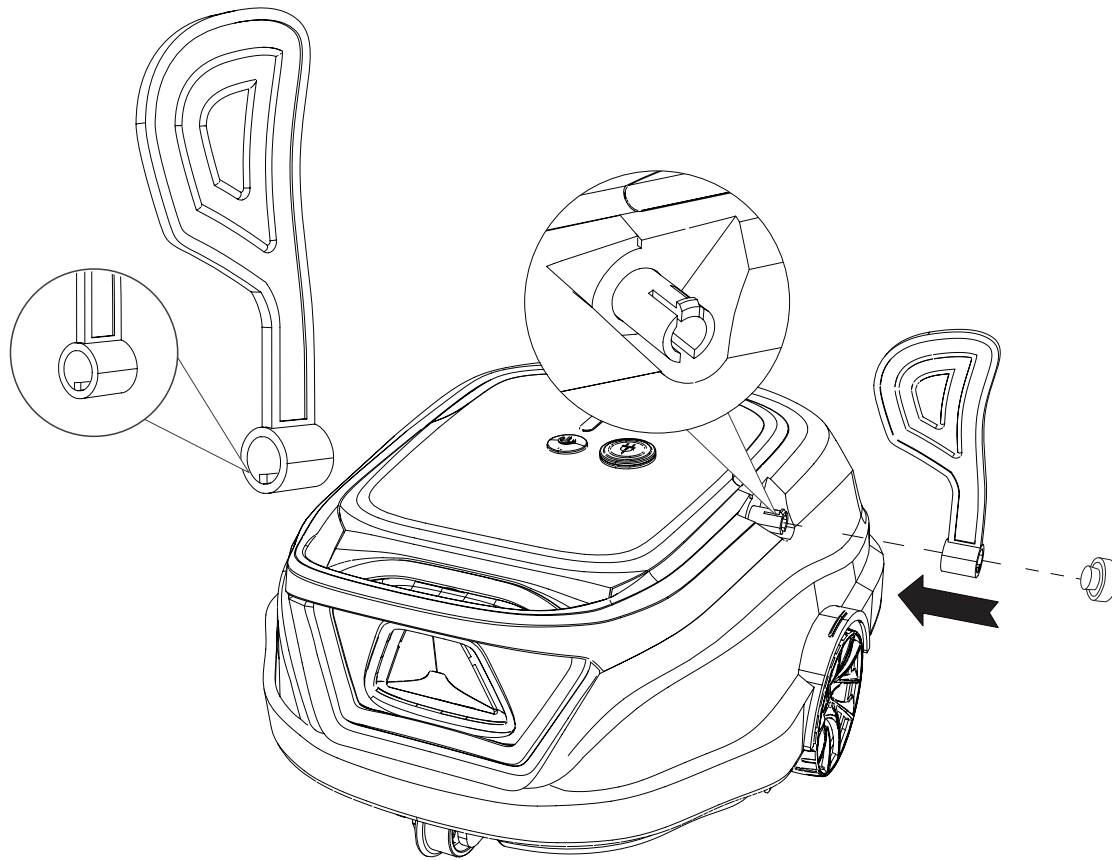

Charge your new Hy-Clor i1

The device has a lithium-ion rechargeable battery, and you need to charge the battery before first use and when the battery is low.

Connect your device to a power outlet using the included cable and adaptor.



Note:

1. When charging, you should ensure your device at least 3m away from the edge of the pool.
2. For reducing fire risk, keep your device and adaptor away from direct sunshine or water when charging.
3. For your safety, you need to double check that the device is powered off and the charging port is dry before charging.
4. The best charging environment is a temperature between 0°C -35°C, RH at 5%-95%.

PRODUCT HELPLINE

AU: 1800 625 123
NZ: (09) 973 2477

help@hyclor.com.au
www.hyclor.com.au



Charge your new Hy-Clor i1 (Continued)

The cleaner can indicate battery level by showing LED lights on the front.

Quantity	Battery Level
●	0 - 25
● ●	25 - 50
● ● ●	50 - 75
● ● ● ●	75 - 100

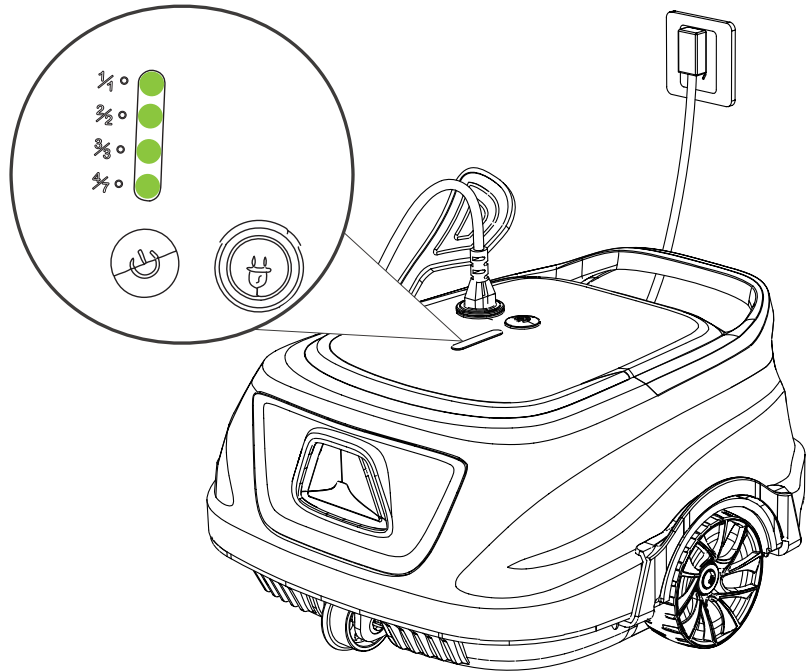

Setup your new Hy-Clor i1

To activate the device, press and hold the on/off button for 1 second. When the device is turned on, the LED indicator on the top will show a solid blue light. Additionally, it will display the current battery level by flashing green for 3 seconds.

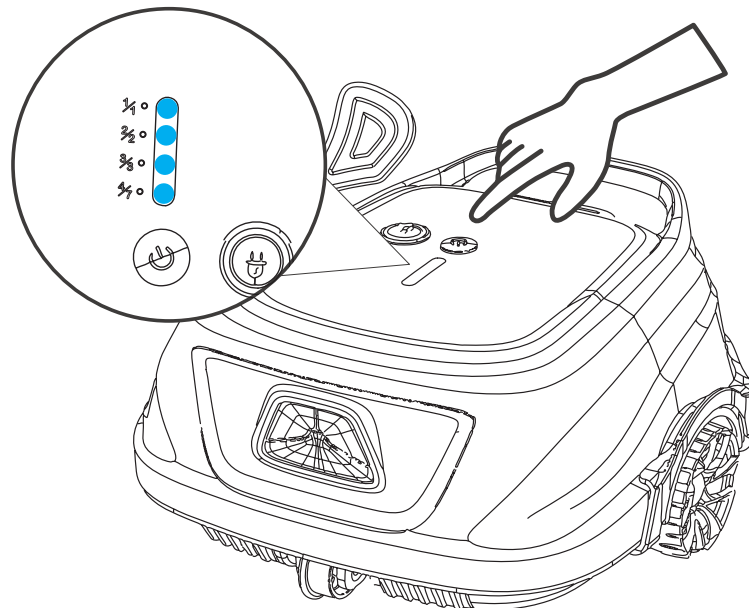

PRODUCT HELPLINE

AU: 1800 625 123
NZ: (09) 973 2477

help@hyclor.com.au
www.hyclor.com.au

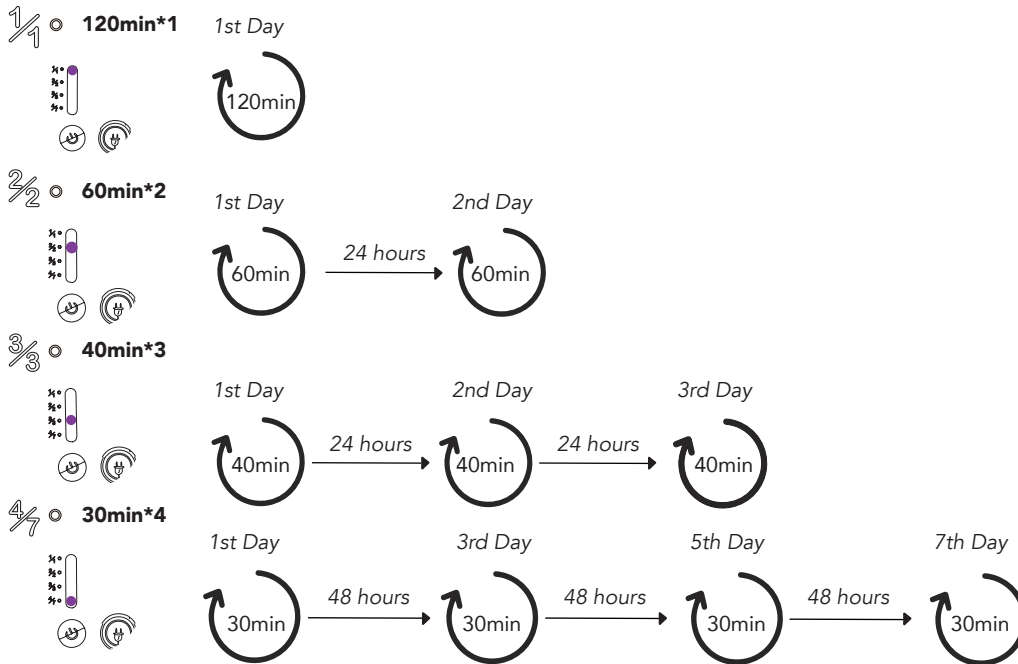

Note:
 If you have selected a cleaning cycle, make sure the cleaner is fully charged beforehand. The default cleaning cycle (1/1) is a single cleaning session lasting up to 2 hours. For other cleaning cycles, ensure the cleaner remains in the pool until the entire cycle is completed. If you power off the device or charge it during the cycle, it will restart the cycle when turned back on.
 If you do not wish to set up a cleaning cycle, simply place the cleaner into the pool while it is on to initiate floor cleaning.

The Hyclor i1 is designed for a user-friendly interaction, and the different LED lights indicate different cleaner status. Please refer to below.

Color	Indication	Status
Blue	Solid	Power on
	Flashing	Cleaner working
Purple	Solid	Cleaning mode selection
Yellow	Flashing	Low battery or self-parking in the pool
Green	Solid	Battery level
Red	Solid or flashing	Fault

Note:
 1. When the LED's flash yellow, remove the device from the water using the retrieval hook. Charge and clean the device. If it is in the middle of a set cycle do not remove the device until the cycle has completed.
 2. If the red LED is on refer to the troubleshooting section or contact Hy-Clor.

PRODUCT HELPLINE

AU: 1800 625 123
 NZ: (09) 973 2477

help@hyclor.com.au
 www.hyclor.com.au



Run your new Hy-Clor i1

After cleaning cycle selection, hold the handle of the i1 and place it into the pool vertically (do not throw into pool)

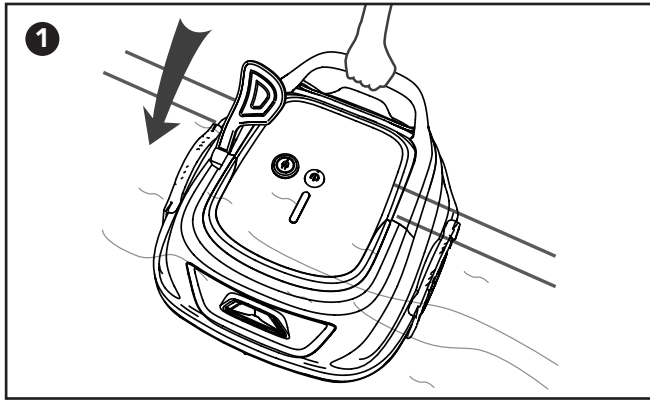

After cleaning cycle selection, hold the handle of the i1 and place it into the pool vertically (do not throw into pool)

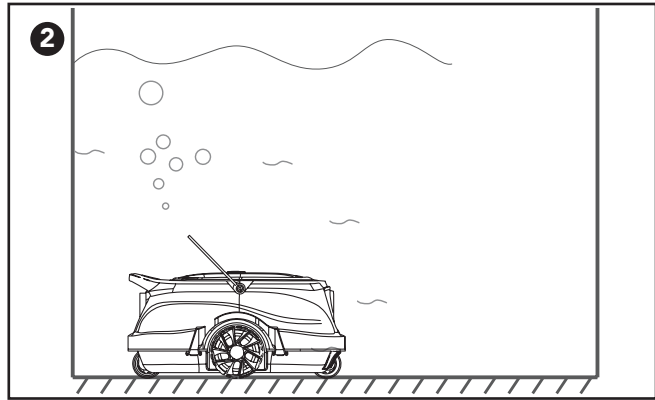

Let it sink down to the floor to empty trapped air inside



Note:

To achieve an optimal cleaning performance, you should ensure the water depth of the pool is at least 50cm high from the top of the device.

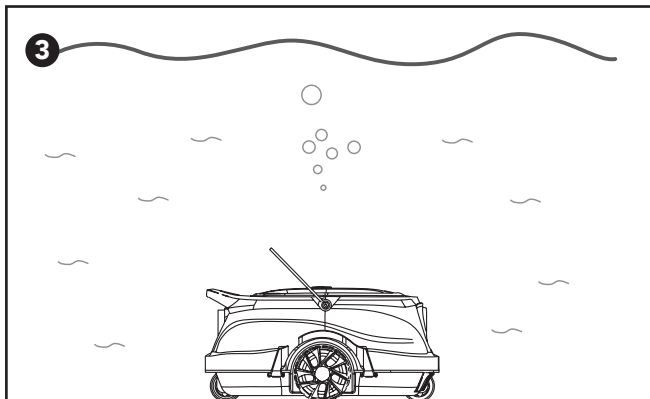

20 seconds of auto calibration on the floor.

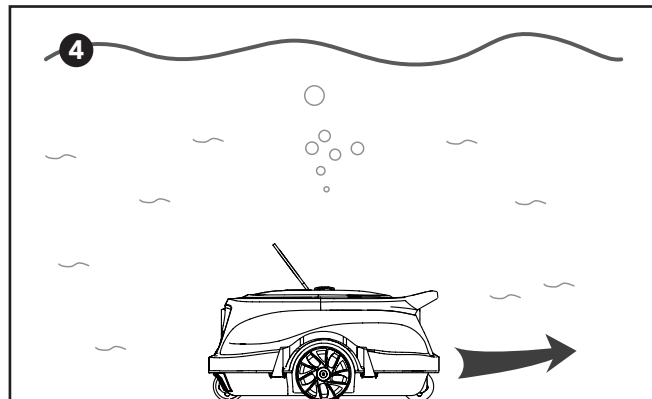

The cleaner begins to clean floor.

PRODUCT HELPLINE

AU: 1800 625 123
NZ: (09) 973 2477

help@hyclor.com.au
www.hyclor.com.au

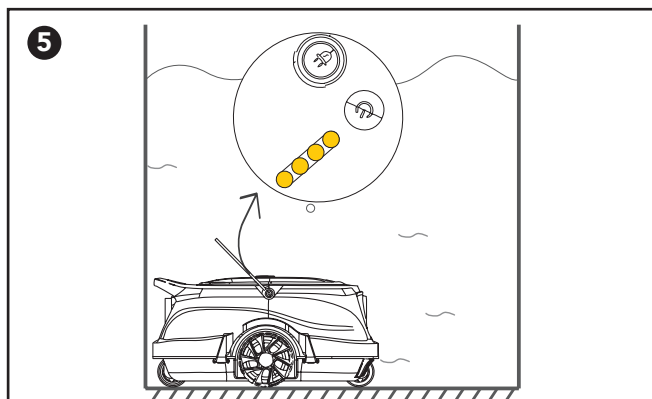

The i1 will automatically move to the edge of the pool when it has finished its cycle or has low battery. It will flash yellow. After 1-2 min it will turn off.

Note: Steep slopes will push the cleaner down when it turns off.

If you have a cleaning cycle set other than 1/1 leave the i1 in the pool to complete the entire cycle.

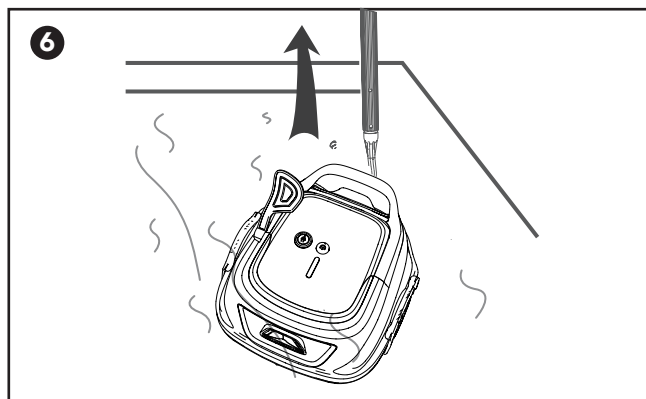

You can insert the included retrieval hook into a pool pole and lift the cleaner out of the pool.

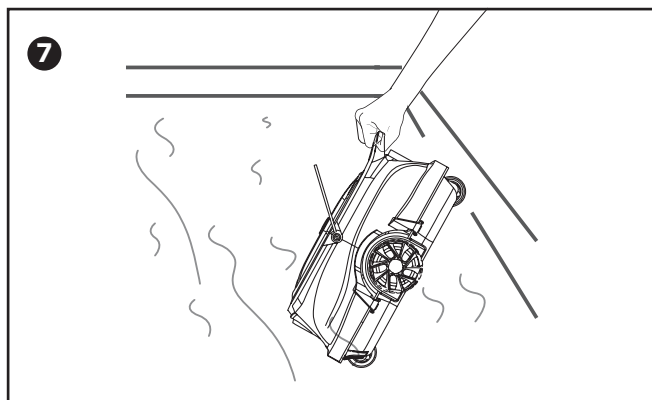

Remove the cleaner from the pool vertically, so that the water drains from the cleaner.



Note:

If you have preset a cleaning cycle other than the default one, you should leave the cleaner in the pool to complete the whole cycle.

PRODUCT HELPLINE

AU: 1800 625 123
NZ: (09) 973 2477

help@hyclor.com.au
www.hyclor.com.au



How to clean the Hy-Clor i1

Remove the top cover by unlocking the fastening clips on each side.

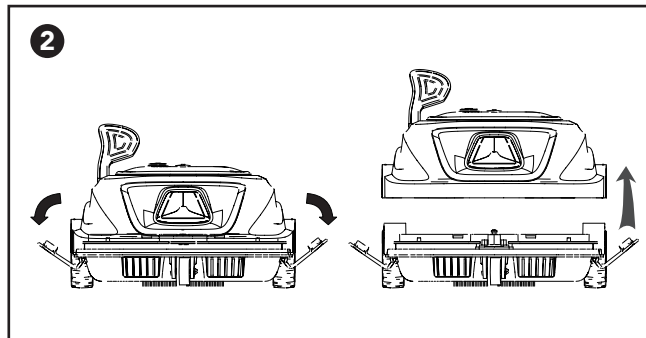
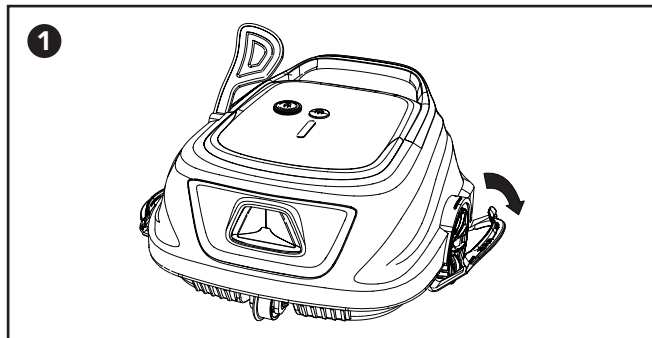

Note:

1. You should ensure the device is powered off when opening the top cover.
2. Clean debris tray and sponge inserts before the cleaner is completely dry - this will assist in the longevity of the cleaner.
3. Give the i1 a wash with fresh water as-well.

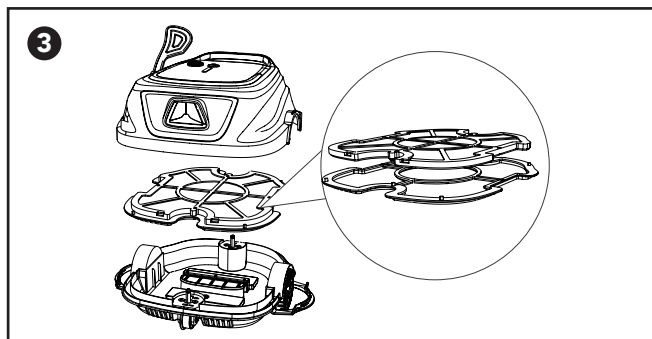

Take out the filter trays.

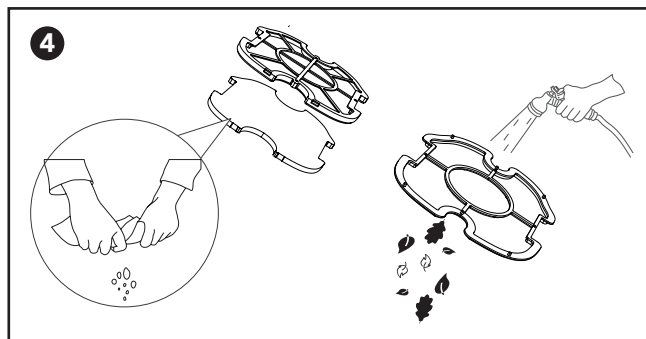

Shake off all debris, and rinse the filter tray with hose water, hand wash the add sponge filter.

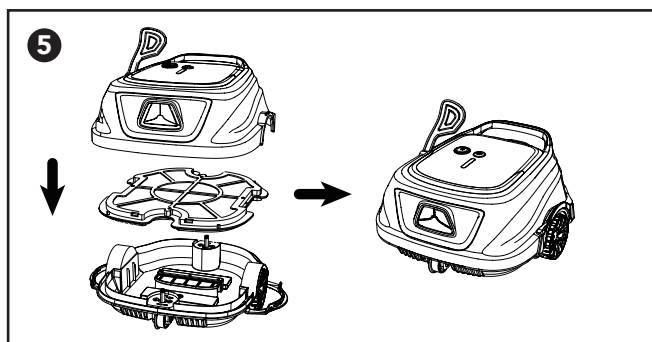

After rinsing, put the filter trays into the cleaner and close the cover.



Note:

The foam insert will discolour over time. The insert may loose its effectiveness over time or if heavy dirt is in the pool. The cleaner is not designed to pick up algae.

PRODUCT HELPLINE

AU: 1800 625 123
NZ: (09) 973 2477

help@hyclor.com.au
www.hyclor.com.au



Device Specification

Model	Hy-Clor i1 Model - HYCROBOTi1
Pool Size	80m ² ~ 100m ² (floor cleaning)
Depth (max)	Max 2.7m & Min: 60cm
Device Dimension	345 (L) * 315 (W) * 170 (H) mm
Weight	3.5Kg
Runtime	Up to 120 min (2 hours)
Charging Time	150min (2.5 hours)
Voltage	Battery/22.2V
Power	Up to 33W
Charger Input	100-240V, 50-60Hz
Charger Output	25.2V/1A
Battery Capacity	2600mAh
Filter Density	180µm + sponge insert
Flow Rate	8.1m ³ /H (l/min)
Moving Speed	up to 16m/min
Water Resistance	IPX8

How to Maintain Your Device

To maintain good performance and prolong the life of your cleaner, follow these steps for storage:

- Make sure the device is powered off.
- Dry out the cleaner and clean the filter basket thoroughly.
- Fully charge the battery before storage.
- Store the cleaner in a cool and ventilated area, away from direct sunlight, heat sources or frost, with an ambient temperature between 5°C and 45°C.
- Charge the cleaner every three months to maintain optimal battery life.



Note:

If your device does not work after a long period of low battery life or being turned off, please contact our after-sales team for assistance. For your safety, do not attempt to dismantle it without authorisation

PRODUCT HELPLINE

AU: 1800 625 123
NZ: (09) 973 2477

help@hyclor.com.au
www.hyclor.com.au



How to Adjust the Cleaning Pattern

If your pool has an irregular shape or if you are not satisfied with the default cleaning pattern, you can adjust the direction of the wheels for better cleaning performance.

Detach the adjustable wheels

You will find two wheel kits marked with A, B, and C on the front and rear sides of the chassis.

To remove the wheel kit:

- This is best done with a small flat head screw driver.
- Locate the catch inserted into the wheel stem.
- Hold the catch and push it towards the inner side, while pushing down.
- Once released, the wheel kit can be removed from the chassis.

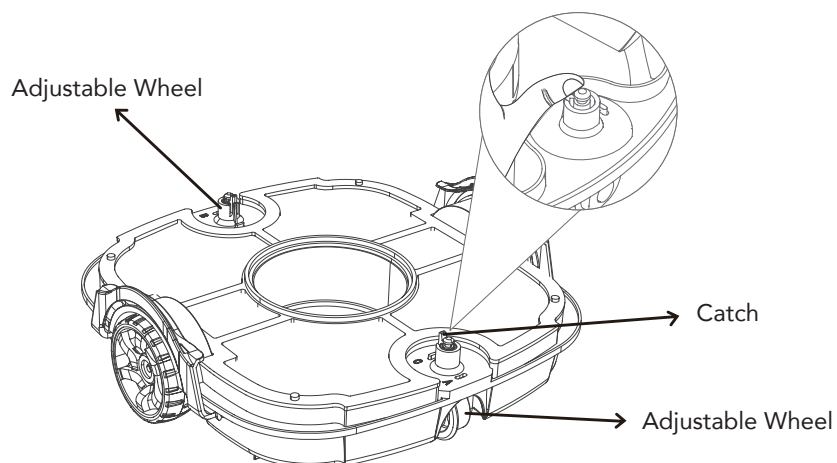

Reset combination path

Insert the limiting lever on the wheel kit into holes marked A, B, and C to modify your cleaning path.

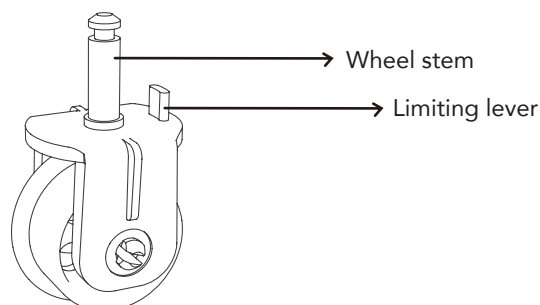

The adjustment wheels can be set to the below combinations:

Combination	Use Scenario
A – B	Default (suitable for most pools)
A – C	Smaller rebounding angle compared to "A – B" suited for longer pools.
B – C	For round shape pools

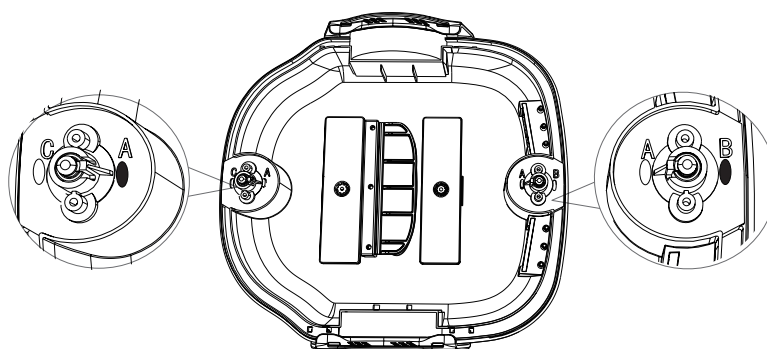

PRODUCT HELPLINE

AU: 1800 625 123
NZ: (09) 973 2477

help@hyclor.com.au
www.hyclor.com.au



FAQ & TROUBLESHOOTING

Q: Is the cleaner able to climb walls?

A: This cleaner is designed for floor cleaning only.

Q: Will obstacles such as steps, shallow water areas, drains, slopes etc. in the swimming pool affect the running?

A: The machine prefers to run on flat floor. High obstacles will block the cleaner.

If you encounter the following situations when using the cleaner, refer to the table provided to troubleshoot the problems.

Symptom	Possible Reason	Solution
Buzzer silent or impeller not rotating after power on	Low battery	Recharge the battery
	Device fault	Contact Hy-clor
The buzzer still sounds or the impeller does not rotate after the cleaner is fully immersed in water.	The flipper is stuck	Remove the cleaner from the pool and try to manually rotate the flipper or contact Hy-clor
	The flipper is not straight or does not move when the cleaner touches the wall.	Reposition the flipper away from the obstruction
The flipper stands still when the cleaner touches the wall, but the cleaner will not reverse	The water channel is stuck	Try to clear foreign objects
Charger indicator does not work or change colour when plugged into the cleaner.	The charger is damaged	Contact Hy-Clor
The cleaner does not cover the entire pool floor.	Improper wheel angel	Adjust wheels position
	Adjust wheels position	Adjust wheels position
	Swimming pool water circulation system is on	Shut down the system

Note: See Page 8 for LED colour indicators.

PRODUCT HELPLINE

AU: 1800 625 123
NZ: (09) 973 2477

help@hyclor.com.au
www.hyclor.com.au



Warranty Terms & Conditions

Our goods come with guarantees that cannot be excluded under the Australian Consumer Law. You are entitled to a replacement or a refund for a major failure and for compensation for any other reasonably foreseeable loss or damage.

Please read these warranty terms and conditions carefully. A failure to comply with these terms and conditions may affect any claim on warranty you may have on a product.

Item	Body/Battery/Motor	Charging Pins	Charger	Consumable parts
Warranty Period	2 Years	2 Years *corrosion is not covered under warranty	2 Years	N/A ** Only initial construction

*Always ensure the charging cap is secure before putting the robot into the pool, charging while the pins are wet will lead to damaging the cleaner this is not covered under warranty. **Always dry the pins before charging.**

**Consumable parts include: Wheels, Filter Basket+ Foam Insert, locking latches, and external roller wheels.

Chemistry plays a major role in the longevity of the external parts of the robot, ensure the pool meets the products specifications.

The warranty may be void if the robot is left in the pool.

Damage to a Vinyl liner is not covered under warranty. It is up to the user to make sure the liner quality is of good quality and will not be damaged using the 'i1' Pool cleaner.

Warranty is only for the Goods included in the box. Shipping fees may apply.

WARRANTY GENERAL CONDITIONS:

All products provided by HY-CLOR AUSTRALIA PTY LTD are warranted for defined periods of time (refer to product table).

All mechanical swimming pool products supplied to consumers by HY-CLOR are to be installed or used in the manner they are manufactured for only.

Warranty may be voided if the product or products claimed by the consumer under warranty have been used for purposes other than their designed or manufactured purpose.

Where applicable, products supplied by HY-CLOR come with operation and installation manuals. All care must be taken to install and operate the products according to these instructions. Failure to install or operate these products in accordance with these instructions may void warranty.

The chemical balance of the swimming pool water plays a significant part in the operational life of all swimming pool products, HY-CLOR recommends regular water testing using an approved swimming pool test kit.

This warranty is valid for the original purchase and is not transferable. Keep your purchase docket, tax invoice or receipt as the proof of purchase, and as proof of the date on which the purchase was made.

Modifications to any electrical product provided by HY-CLOR products are covered by a twelve-month warranty unless prior written approval has been granted by HY-CLOR and has been carried out by one of its authorized agents. All electrical installations must be carried out by a competent licensed professional.

All pool filtration equipment including filters, pumps and salt chlorinators, must be kept in a dry well ventilated area away from direct sunlight and in an area that is free from flooding or rain. This warranty does not cover normal wear and tear to the products or parts.

To make a claim please contact:

HY-CLOR AUSTRALIA PTY LTD
178 POWER STREET
GLENDENNING NSW 2761
FREE CALL NUMBER 5 DAYS A WEEK 1800 625 123.

PRODUCT HELPLINE

AU: 1800 625 123
NZ: (09) 973 2477

help@hyclor.com.au
www.hyclor.com.au



HY-CLOR AUSTRALIA PTY LIMITED
ABN 81 000 655 381

178 Power Street
Glendenning NSW 2761 Australia

AU 1800 625 123
NZ (09) 973 2477

help@hyclor.com.au
hyclor.com.au